

PROVIDE CLARITY



Filtration solutions for water & wastewater treatment plants



Maximum system protection. Minimal operating costs.

## Filtration specialist: BOLL & KIRCH

Highest filtration quality and guaranteed process reliability in water & wastewater treatment plants - the self-cleaning fully automatic filters from BOLL & KIRCH make it possible. As an industry leader in technology we have specially adapted to processes in this market, BOLL & KIRCH offers integrated solutions based on comprehensive application experience. We consistently meet the complex process conditions with application-oriented engineering, whereby continuous

operation and protection of your plant and processes are always in the foremost. With the help of high-quality components, flexible coatings and different filter element options, we implement the best possible solution for your individual application needs.

The overall plant efficiency of your water & wastewater treatment processes are significantly improved by long service life and successful operation service of the filters used.



# Our expertise for your filtration process

## Automatic Filter aquaBoll®

The aquaBoll® automatic filter is based on a principle especially designed for water filtration: The multi-part housing design with variations in filter elements – filter cartridges, sieve cylinders and fine sieve cylinders – enables selection of performance specific efficiency. This is achieved by the backwashing process taking place parallel to the filtration process. Thus aquaBoll® easily meets the complex requirements of water and wastewater treatment. The variance in BOLL design options, reduces risks in commissioning and maintenance expense, standardized interchangeability components ensure maximum reliability, and limit downtime and significantly increase the overall system efficiency of your process.



## BOLLFILTER Automatic Type 6.04

The BOLLFILTER Type 6.04 is the ideal filter in the field of water treatment for flow rates of up to 18m<sup>3</sup>/h. Due to the very compact design and the use of individual filter elements, an uninterrupted filtration process is also possible with the 6.04. Your system components can be reliably and effectively protected with high-quality woven mesh and inverted wedgewire in the filtration range from 500µm to 30µm.



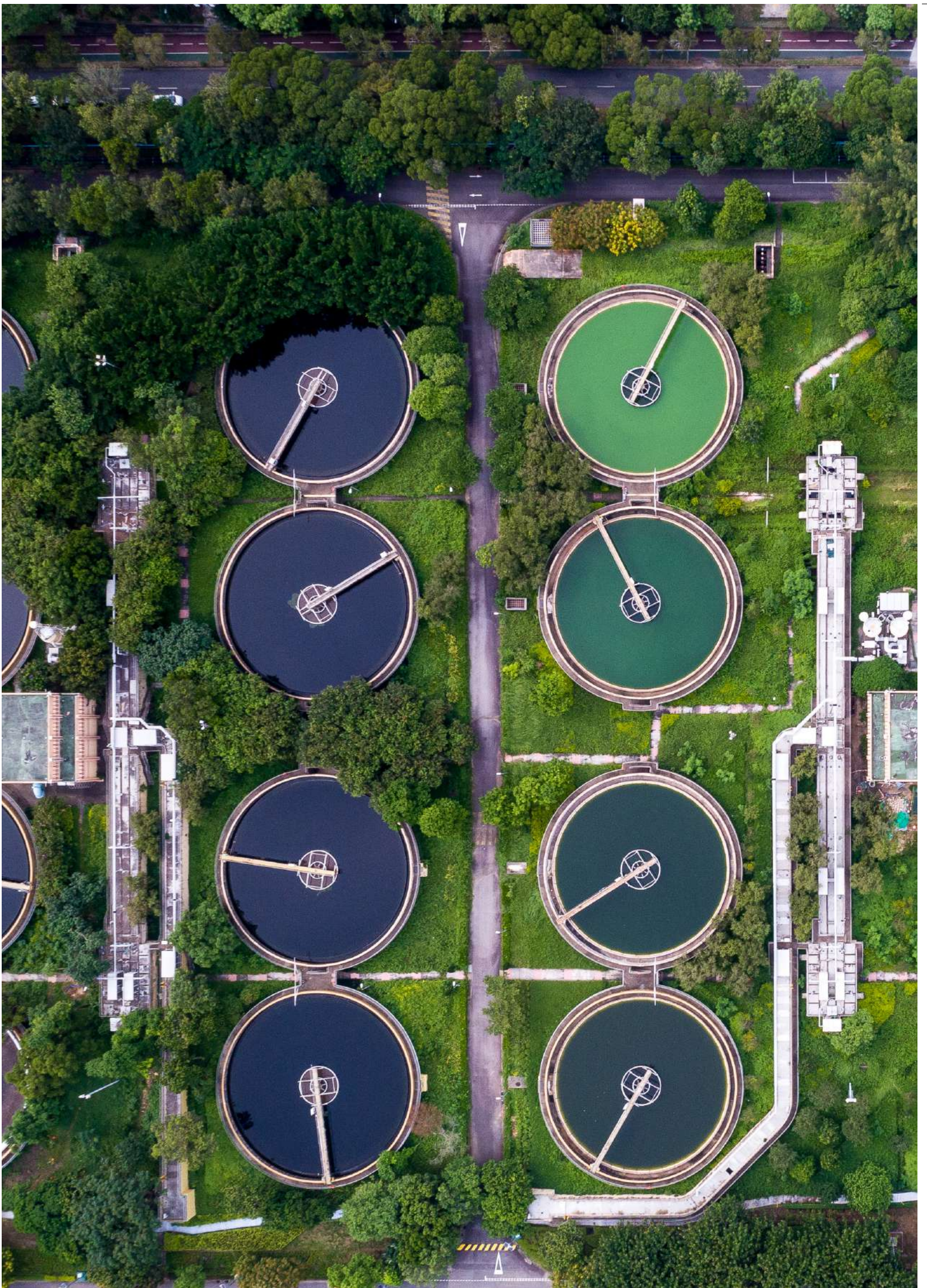



## Sewage plants

The treatment of wastewater in sewage treatment plants is a comprehensive process for the removal of pollutants from suspended solid non-potable water, which mainly comes from municipal areas. Mechanical, chemical and biological processes for the production of environmentally friendly and purified process water play an important role in maintaining water resources.

The BOLLFILTER serves as a key component in systems in mechanical treatment for the effluent water for particle removal, so that, for example, the COD value for return to open waters can be maintained. The additionally produced process water is reused for various

applications within the wastewater treatment plant. In order to ensure fail-safe treatment of the respective waste water throughout the entire process, exact filtration results and long service life of the filtration solutions have top priority. Increasingly, municipal wastewater is being reused together with industrial wastewater in large wastewater treatment plants in order to achieve economically viable operating costs. The operation of such larger, combined systems does not only mean reduced relative operating costs, but also increased demands on the filtration solutions used.

mechanical / biological and  
chemical clarification stage ►



Exact qualities of the  
purified process water



# Flexible filtration solutions for demanding clarification processes

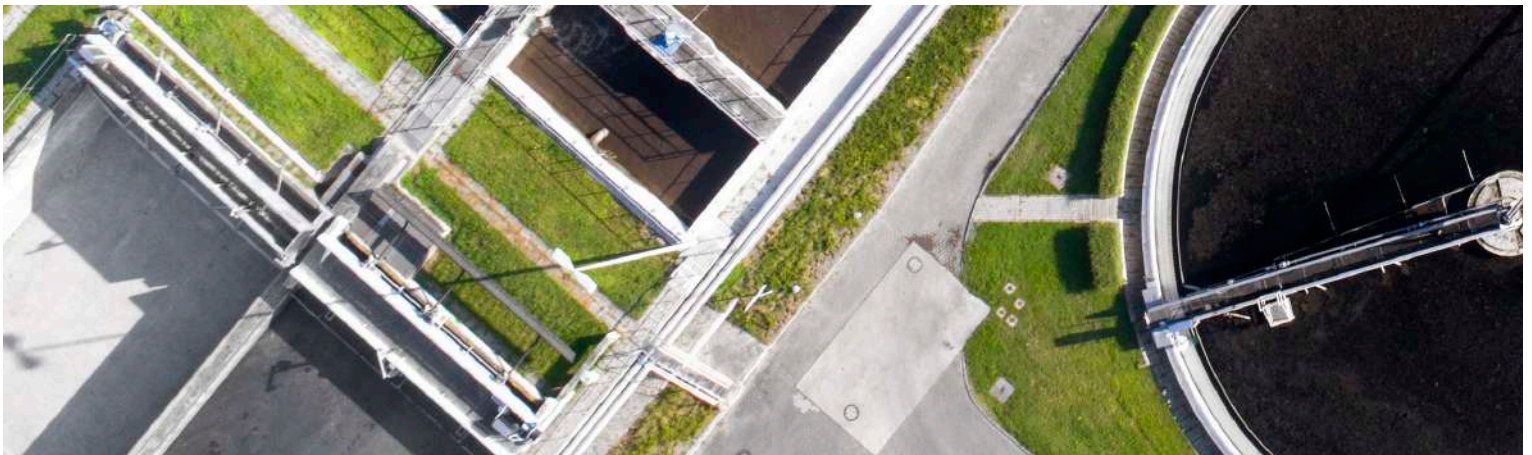
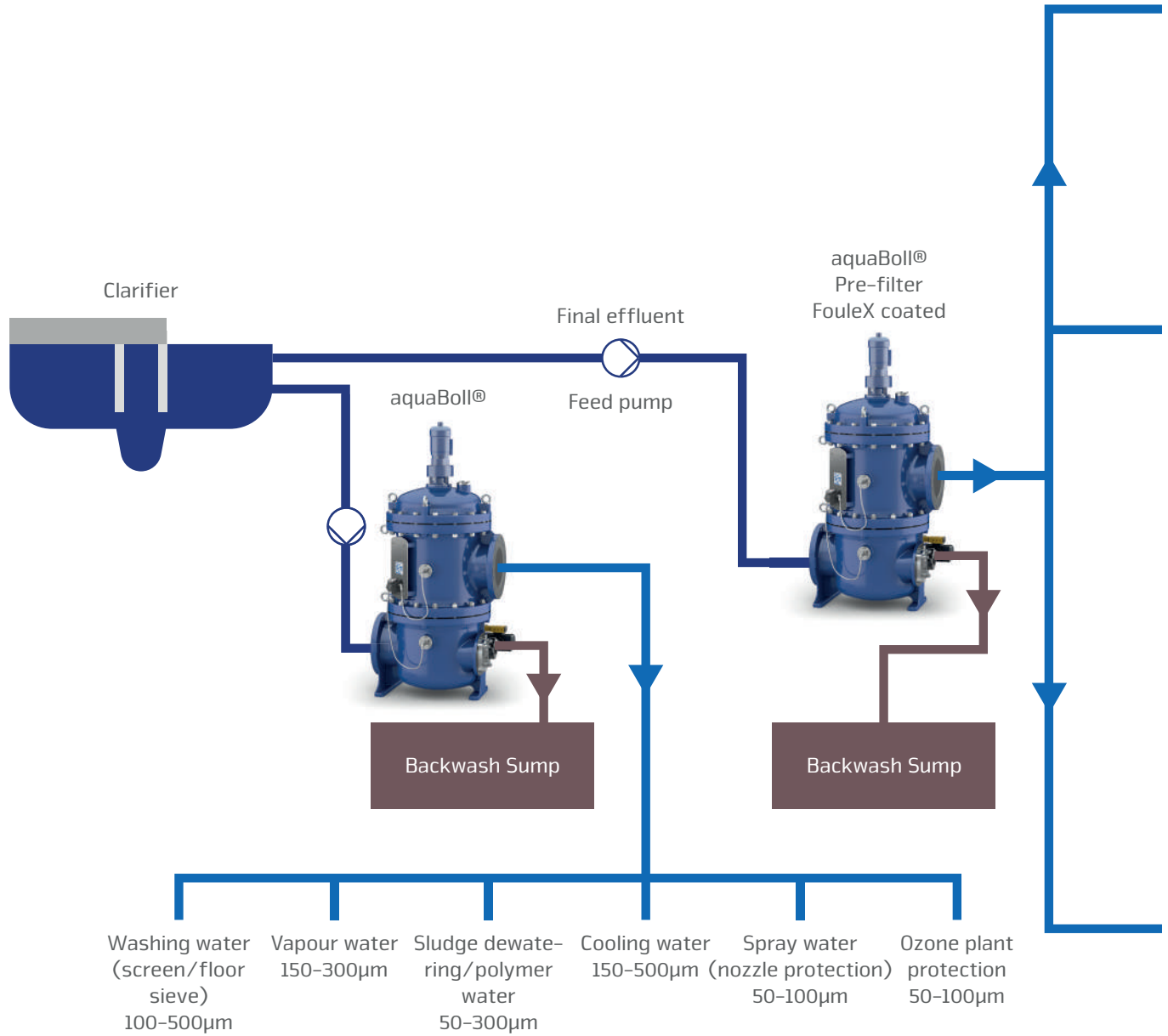

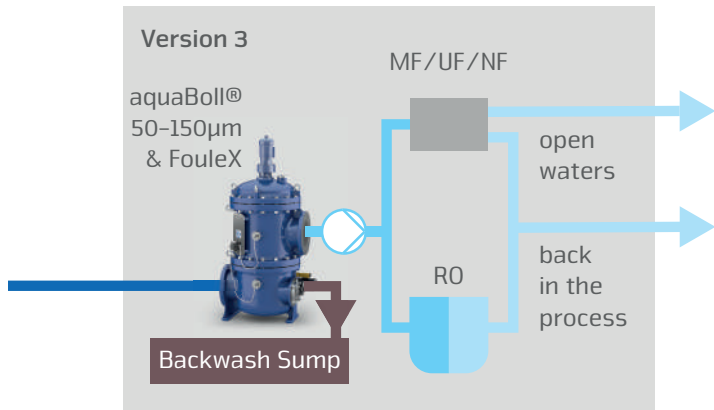
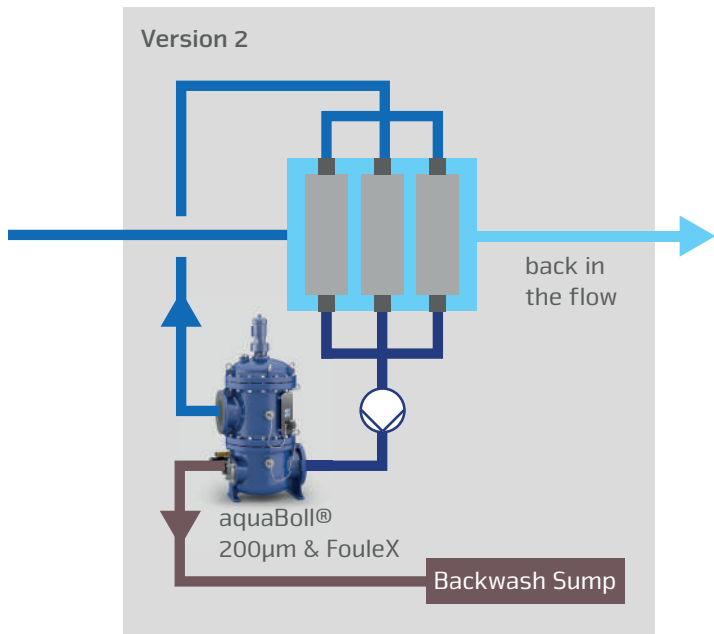
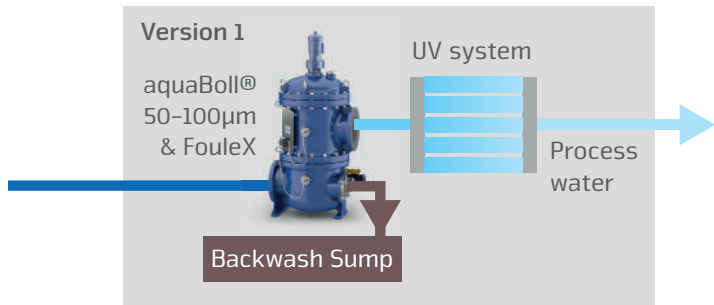

## Waste water treatment for process use or recirculation

Self-cleaning strainers from BOLL & KIRCH are specially designed for the complex challenges in wastewater treatment plants of different capacities. The comprehensive customisation of the components used and high-quality overall components enable application solutions that lead to optimised plant operation in every configuration. Different fine filter elements can be implemented according to the desired rate of filtration. The proven antibacterial FouleX® coating reduces the adhesion of biomass particles to the elements. This ensures that the entire wastewater treatment process is maintained and efficient at all times.

### Main benefits:

- Extension of the plant service life
- Increased overall plant efficiency
- Reduce operating costs while increasing productivity





## Drinking water

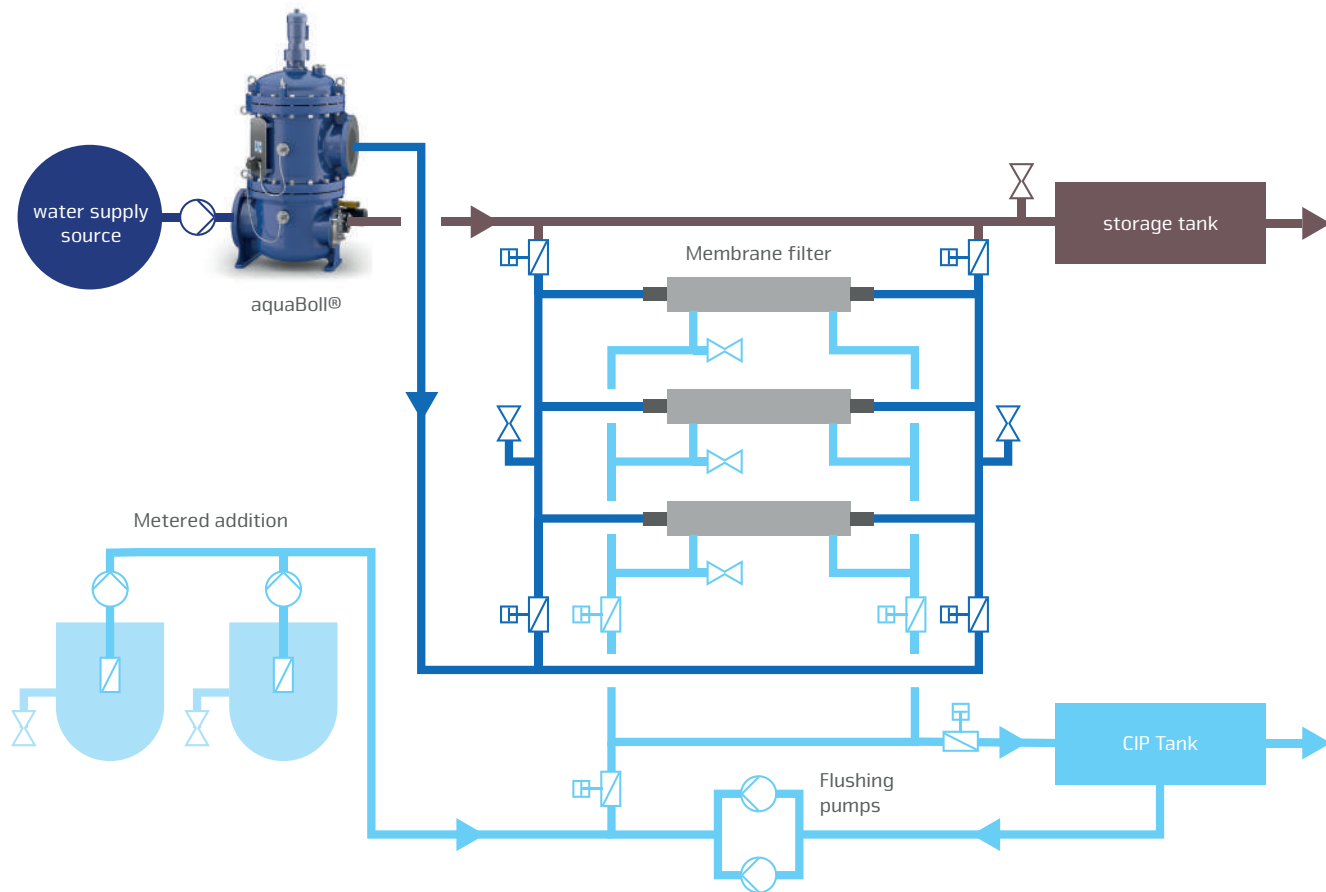

### Protection of membrane filtration plants

Maintain complex drinking water treatment processes at low cost: Automatic filters from BOLL & KIRCH are pre-filters with high filtration quality and automatic backwashing to protect your system. The actual treatment process of the drinking water in the membrane plants can remove thus be efficiently maintained by an overall removal and extended run time. This confirms the fact that operators of large water treatment plants and membrane manufacturers have been using BOLL & KIRCH automatic filters for several years.

This interaction gives the term „high water quality“ a completely new meaning – people, environment and system benefit holistically.

#### Main benefits:

- Extension of membrane and plant service life
- Increased overall plant efficiency
- FouleX® coating minimises maintenance costs







Drinking water quality  
at the highest level

RO SKID  
# 3  
(3-R0-3)

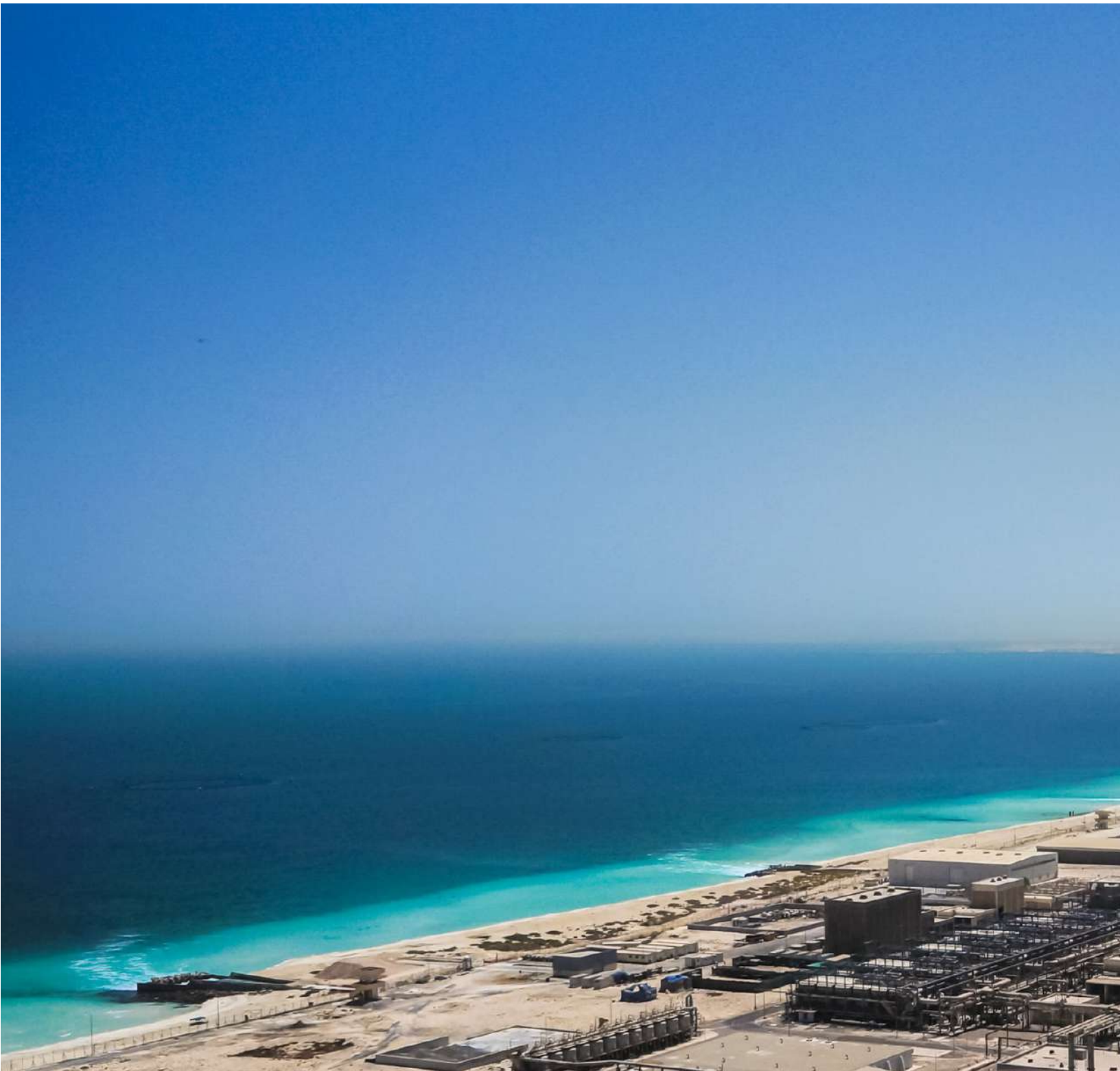

Process stability through  
guaranteed membrane protection





# Desalination

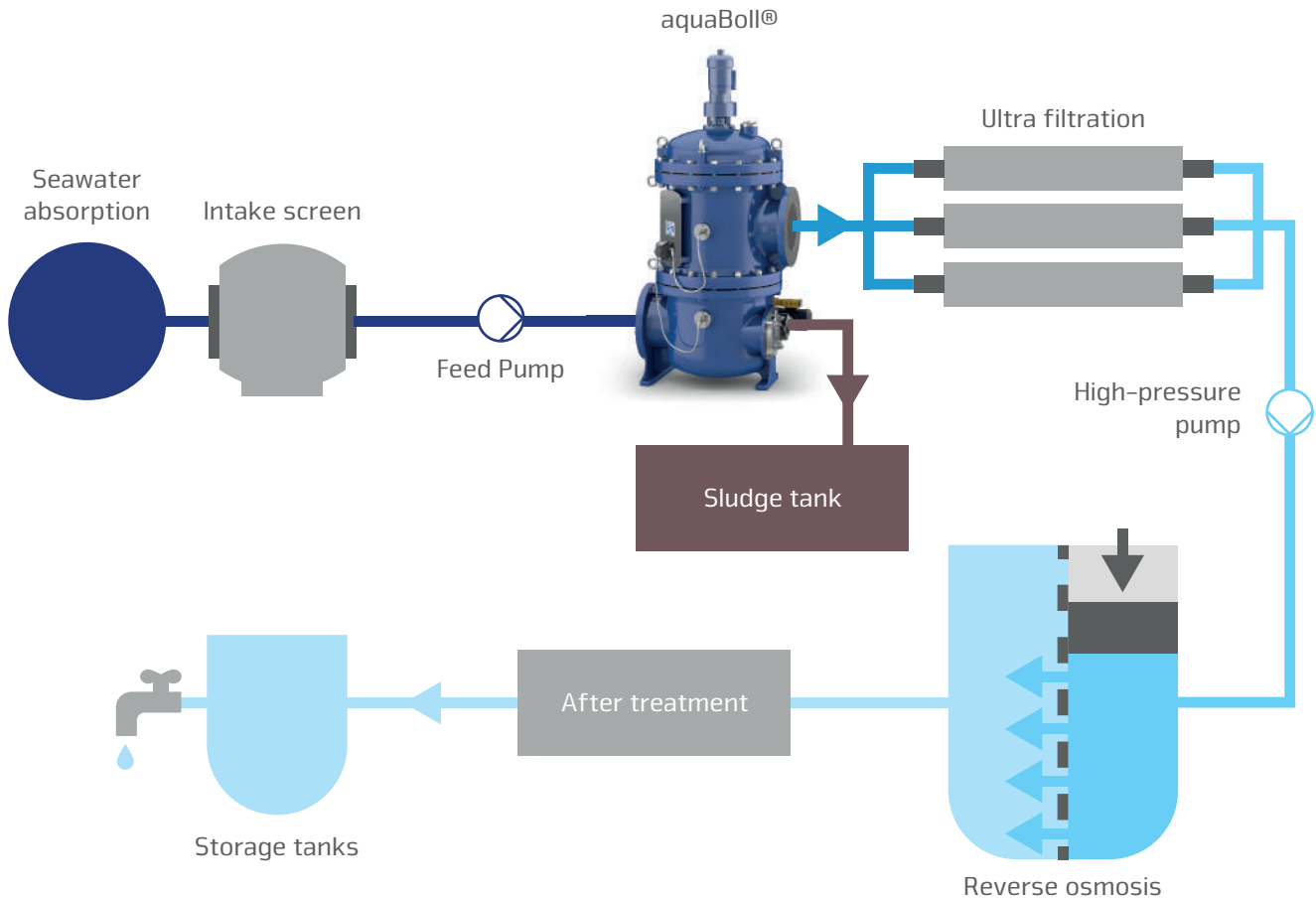

## Protection of reverse osmosis plants in desalination processes

Continuous seawater desalination through permanent plant protection – an operating condition effectively guaranteed by automatic filters from BOLL & KIRCH. As pre-filters for ultra filtration and reverse osmosis, our self-cleaning filtration solutions reliably remove impurities from the seawater and enable efficient continuous operation of the membrane systems downstream in the process in the system. Increasing the service life of the membranes contained therein is a top priority, as they represent the most sensitive and at the same time most expensive part of the filtration process.

The guaranteed filtration quality of our automatic filters ensures at all times sustainably the overall plant performance of the desalination process. Compared to conventional filtration solutions for the protection of desalination plants, automatic filters from BOLL & KIRCH offer innovative solutions and a number of advantages:

- optimised space requirements and minimal operating costs
- extended membrane and system service life
- Foulex coating minimises maintenance costs





Make use of our expertise in complex filtration processes and increase the efficiency of your specific application process! Our self-cleaning automatic filters ensure efficient system protection and a significant reduction in downtime costs. In addition to the implementation of application optimisation through filtration solutions, customers rely on the flexibility of our processes and appreciate our individual support and guaranteed worldwide service.

- comprehensive application expertise in the field of water & wastewater treatment
- Fastest product availability
- Highest level of technological reliability

### Australian Distributor

CAPS Australia Pty Ltd

Inquiries: 1800 800 878

Website: [caps.com.au](http://caps.com.au)

Email: [info@caps.com.au](mailto:info@caps.com.au)



### Manufacturer

Boll & Kirch Filterbau GmbH

Siemensstraße 10 – 14

50170 Kerpen

Telephone: +49 2273 562 0

Fax: +49 2273 562 223

Email: [info@bollfilter.com](mailto:info@bollfilter.com)

[www.bollfilter.com](http://www.bollfilter.com)

